

Supergrid or Local Network Reinforcements, and the Value of Controllability – An Analytical Approach

Spyros Chatzivasileiadis, Thilo Krause and Göran Andersson

ETH Zurich, Switzerland



IRENE-40 European Project

- Infrastructure Roadmap for the **E**nergy **N**etworks in **E**urope for the next **40** years

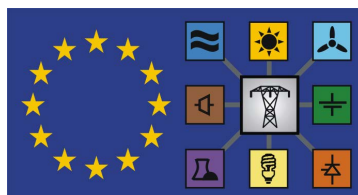

www.irene-40.eu

- Identify expansion measures with respect to:
 - Sustainability → more RES
 - Security
 - Competitiveness → efficient market operation

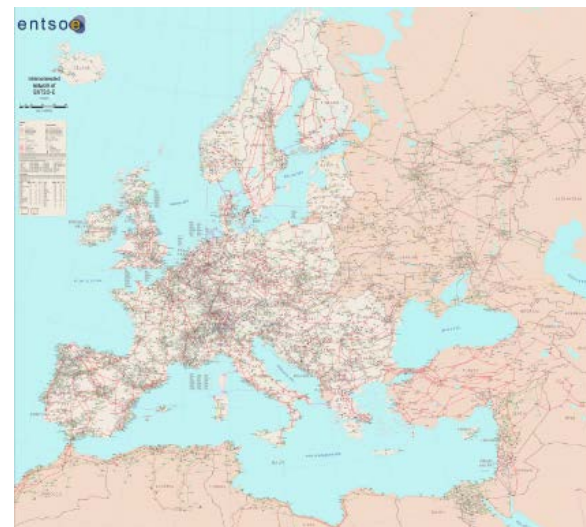

Supergrid or Local Network Reinforcements?

Supergrid

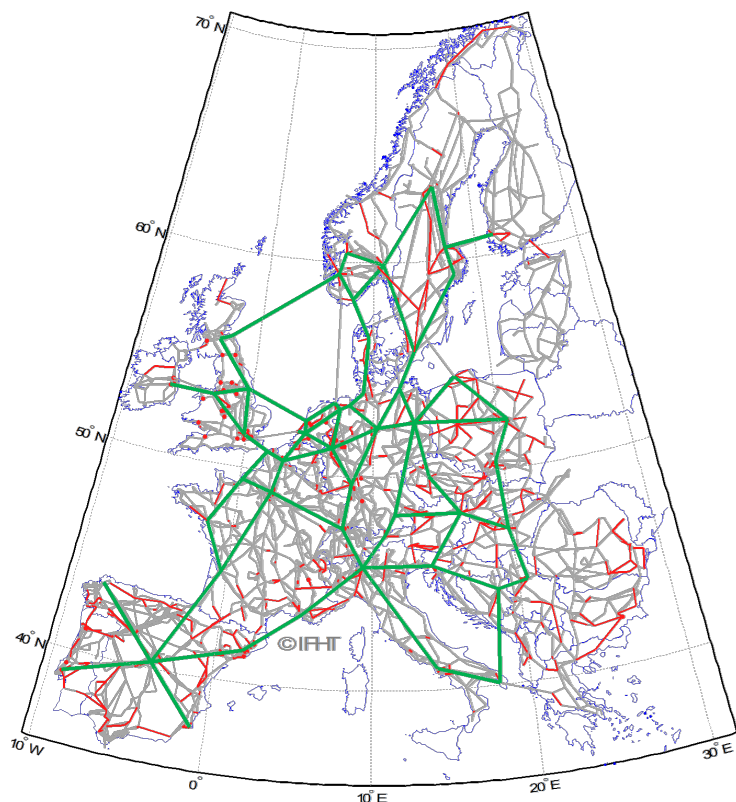

Local Reinforcements

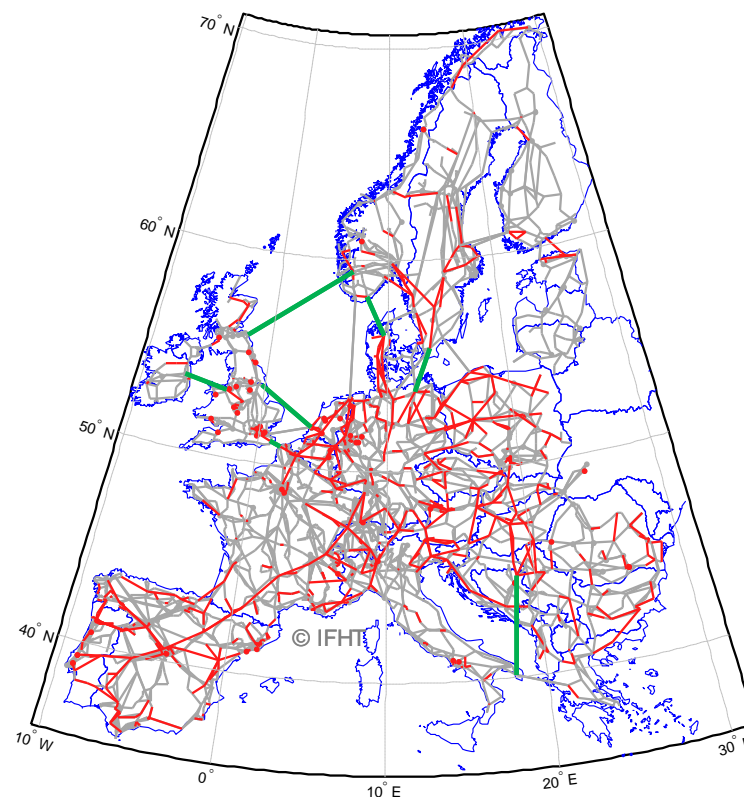

source: irene-40.eu (RWTH Aachen)

AC or HVDC ?



OUTLINE

AC Expansion

1. Derivation of the Analytical Relationships

- Supergrid vs. Local Reinforcements
- Upper bound on utilization of AC Overlay Lines

2. Case Study: RTS-96 Two-Area System

AC vs. HVDC

3. Yearly Simulations on European Network

4. Conclusions

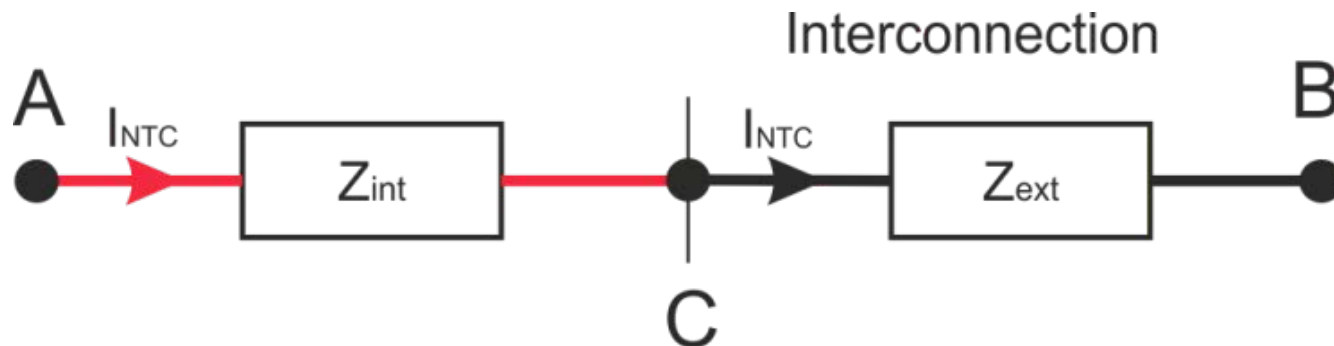
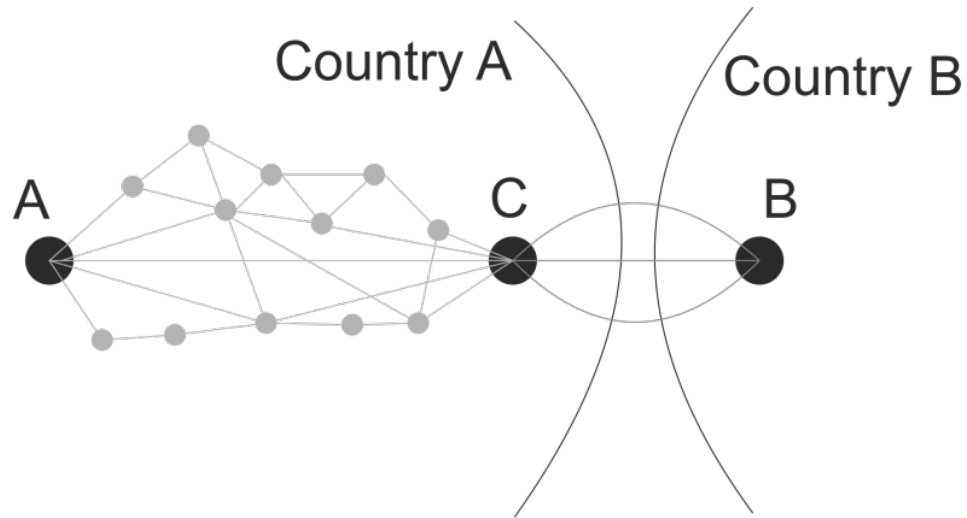

Assumptions

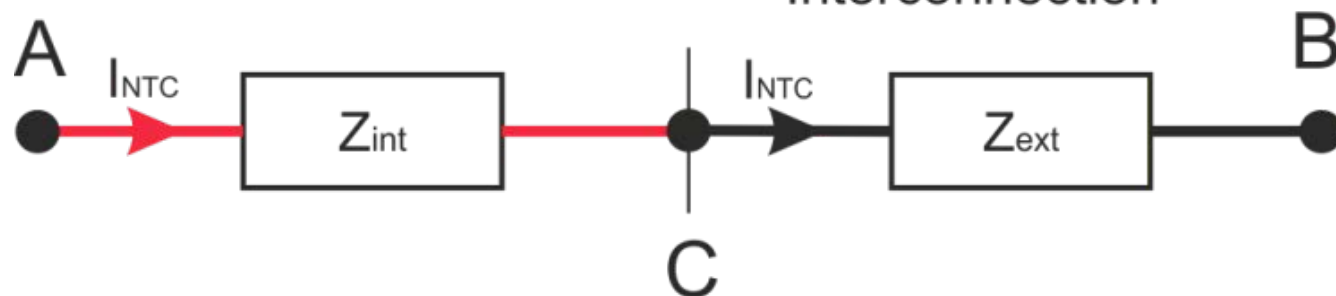
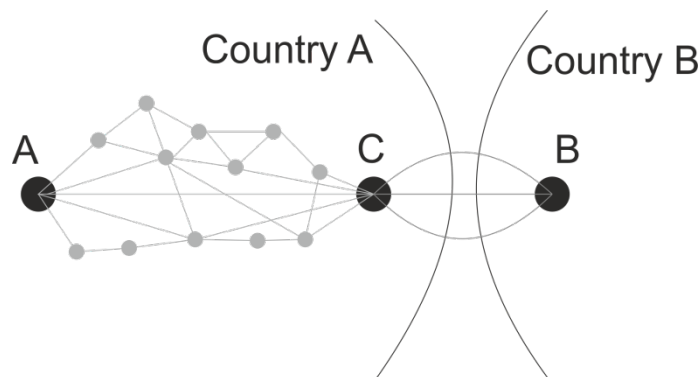

#1

Internal Network more meshed than the Interconnection

$$Z'_{int} \leq Z'_{ext}$$

← per unit length

#2

NTC (I_{NTC}) is determined due to congestions in the internal network

← The bottleneck is not in the interconnection

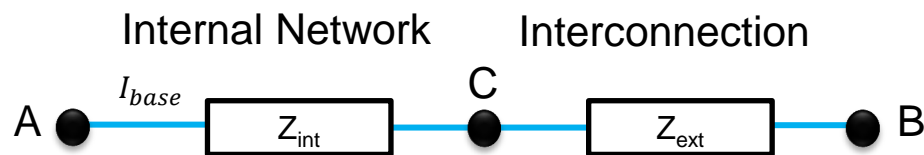

- Adding the same line as internal reinforcement or parallel to the interconnection

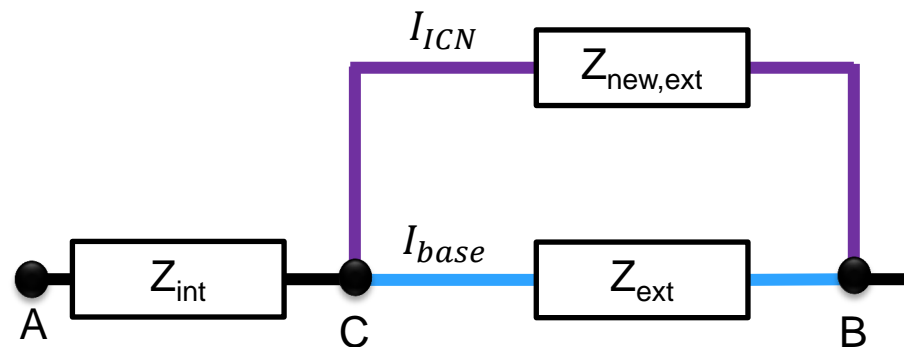
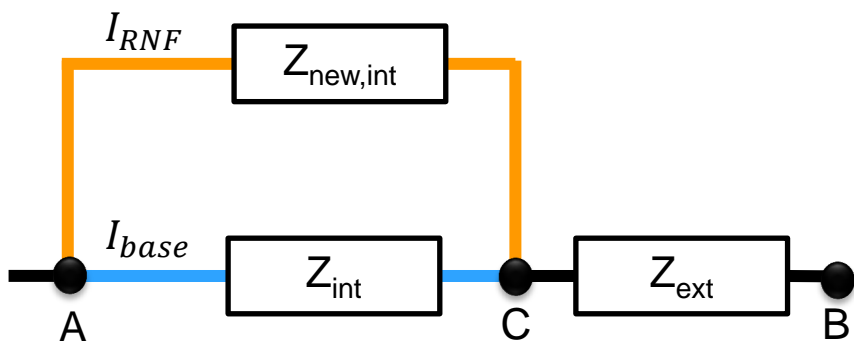

$$\frac{Z'_{int}}{Z'_{new,int}} \leq \frac{Z'_{ext}}{Z'_{new,ext}}$$

$$I_{RNF} = \frac{Z_{int}}{Z_{new,int}} I_{base}$$

$$I_{ICN} = \frac{Z_{ext}}{Z_{new,ext}} I_{base}$$

Flow through the internal reinforcement

$$I_{RNF} \leq I_{ICN}$$

Flow through the line parallel to the interconnection

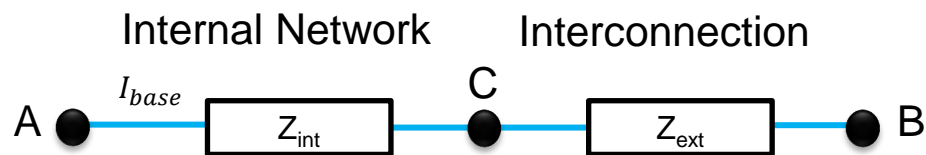

- Adding the same line as *overlay line*

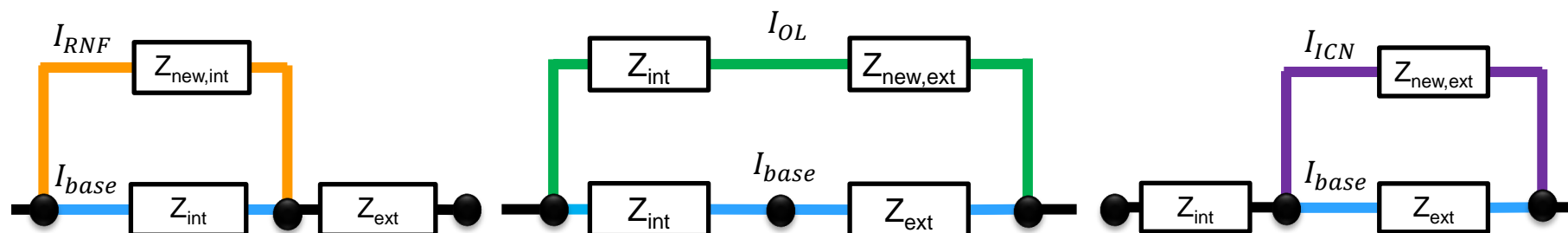

$$\frac{Z_{int}}{Z_{new,int}} \leq \frac{Z_{int} + Z_{ext}}{Z_{new,int} + Z_{new,ext}} \leq \frac{Z_{ext}}{Z_{new,ext}}$$

Flow through the internal reinforcement

$$I_{RNF} \leq I_{OL} \leq I_{ICN}$$

Flow through the line parallel to the interconnection

Flow through the overlay line

Supergrid vs. Internal Reinforcements

- Add same line as *internal reinforcement* or *overlay line*
- Assume that the existing network has transfer capacity limited to I_{NTC}

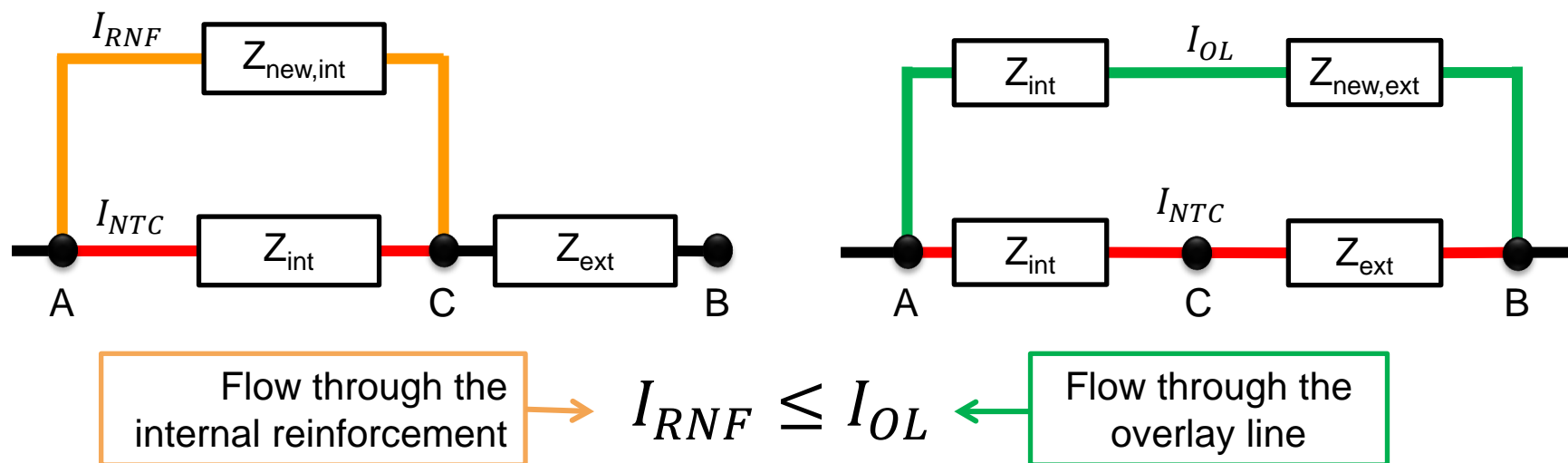

Overlay networks lead to higher utilization compared with internal reinforcements

Overlay Networks: Upper bound on utilization

- Assume that the existing network has transfer capacity limited to I_{NTC}

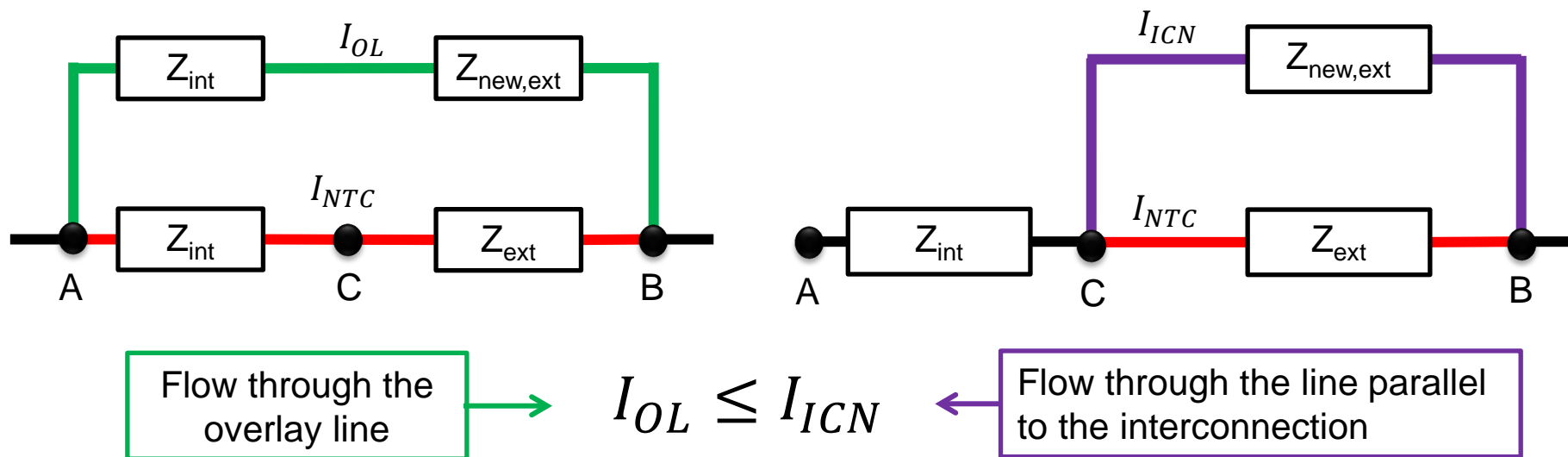

Upper bound on utilization for overlay networks:
Line with equal length and parallel to the interconnection

Overlay Networks: Upper bound on utilization

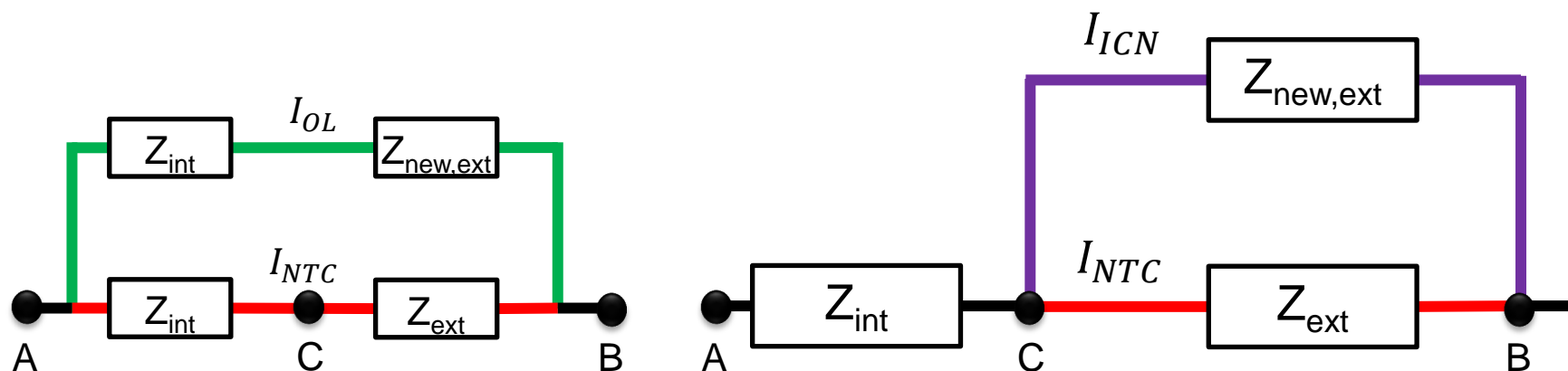

$$I_{OL} \leq I_{ICN}$$

- Existing interconnection: at least on AC-400 kV line
- Adding one cross-border AC-400 kV: $I_{OL} \leq I_{NTC}$
- Adding one cross-border AC-750 kV: $I_{OL} \leq 1.6 \cdot I_{NTC}$

Wrap-up

Assumptions:

- Weakly interconnected meshed networks
- Bottlenecks are inside the networks (not on interconnections)

Findings:

- Overlay networks are preferable: they carry more power for the same line-kilometers compared to local reinforcements
- Upper bounds for AC overlay networks:
 - One additional cross-border AC-400 kV:
 - Total NTC cannot increase more than twice
 - One additional cross-border AC-750 kV:
 - Upper bound for total transfer capacity is $2.6 \cdot \text{NTC}$

OUTLINE

AC Expansion

1. Derivation of the Analytical Relationships
- 2. Case Study: RTS-96 Two-Area System**

AC vs. HVDC

3. Yearly Simulations on European Network
4. Conclusions

IEEE RTS-96 Two Area System

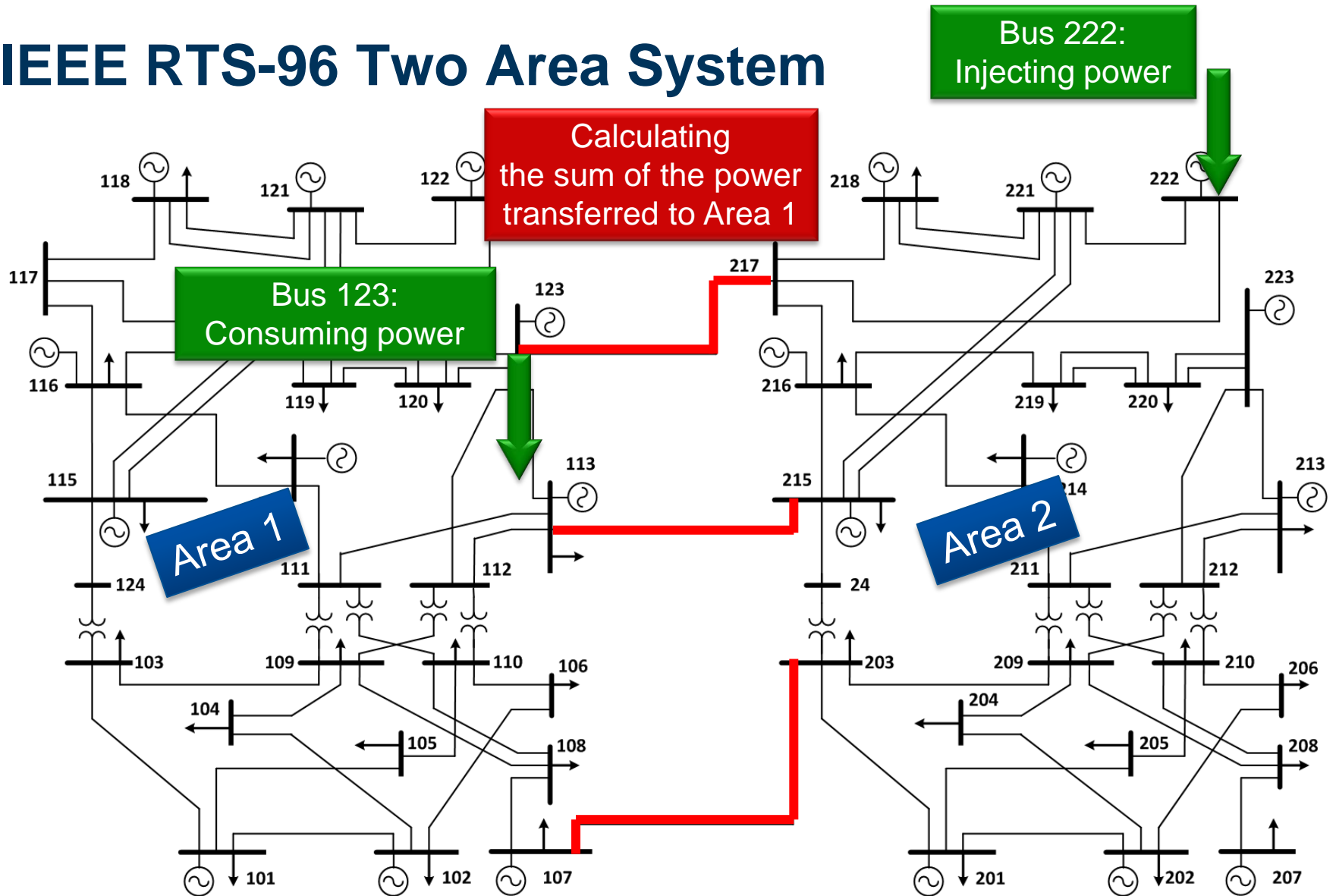

Case Study: Maximum Power Transfer from Bus #222

1. Set bus #222 as slack bus
2. Increase active power consumption at Bus #123 in steps of 50 MW
3. Run DC Power Flow
4. Calculate the sum of the power flows over the interconnections
5. If no congestion in the internal network of Area 2, go to Step 1

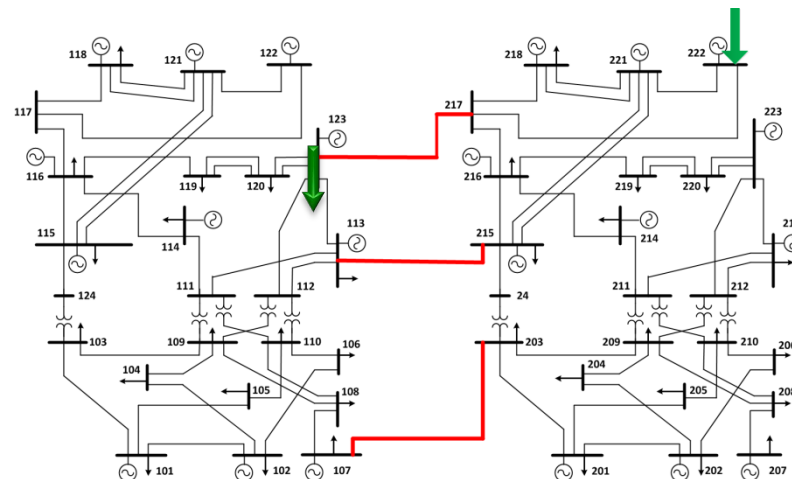

IEEE RTS-96 Two Area System

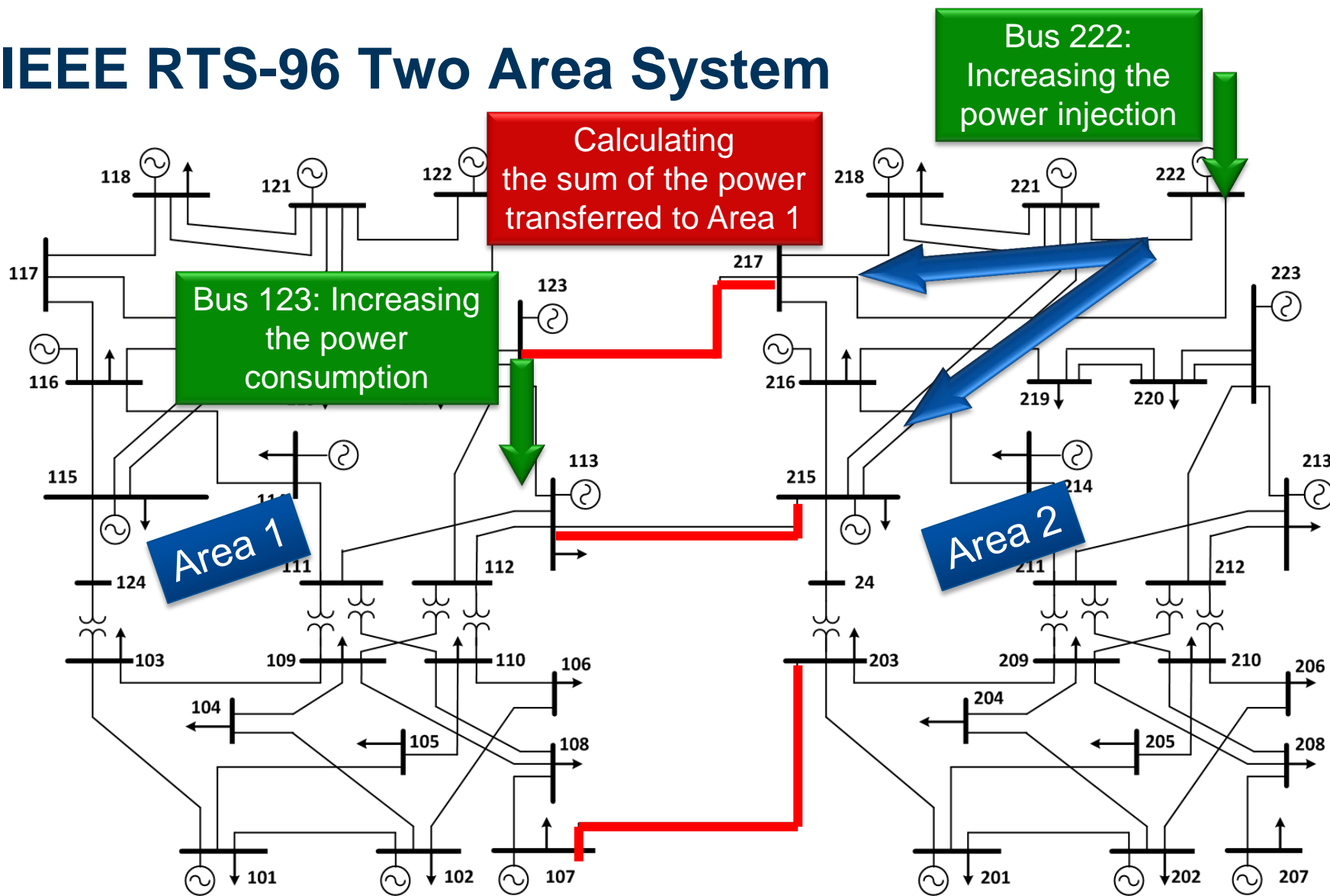

Overlay vs. Local Reinforcements

One existing interconnection (230 kV)

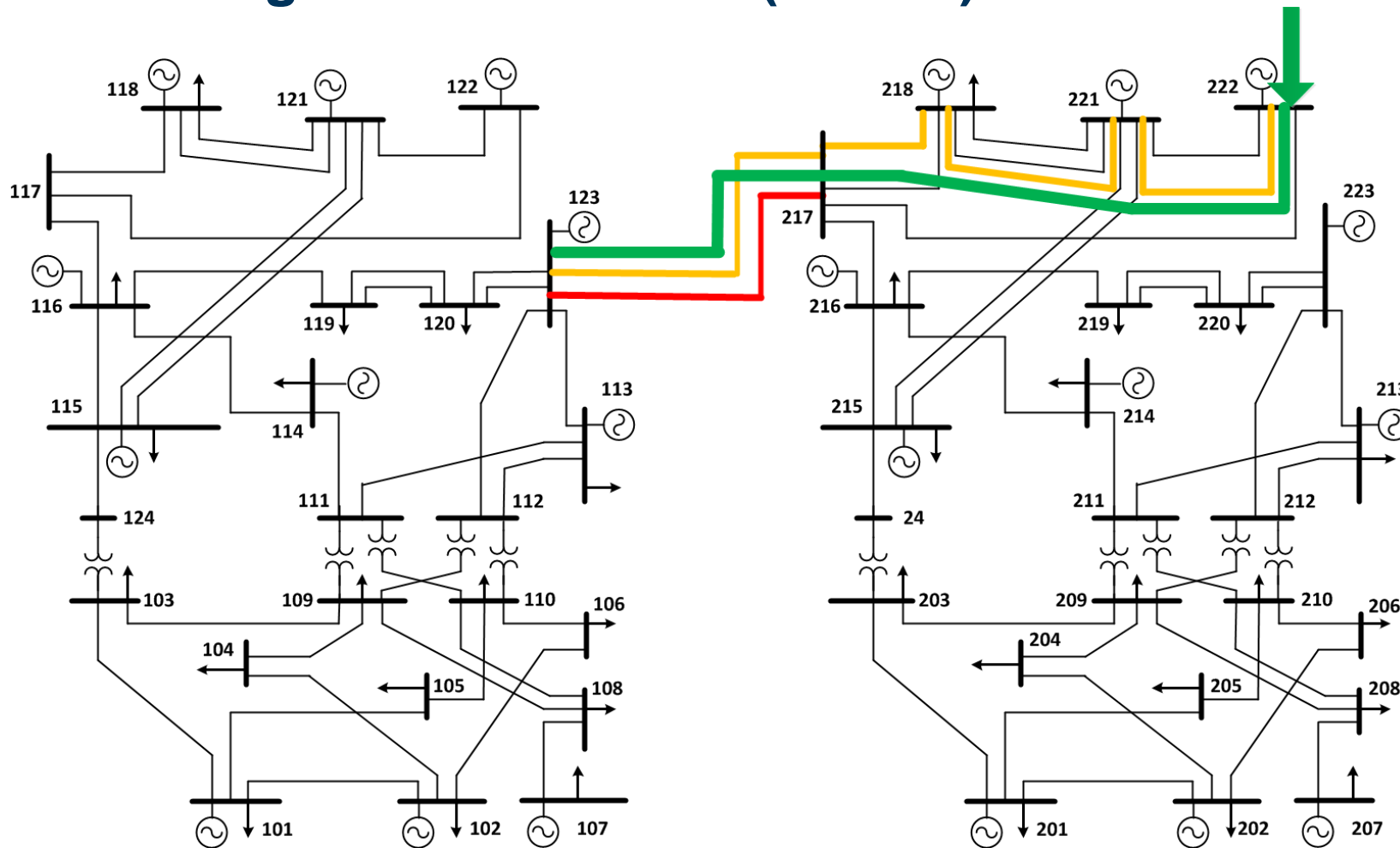

Overlay vs. Local Reinforcements

Two existing interconnections (230 kV & 138 kV)

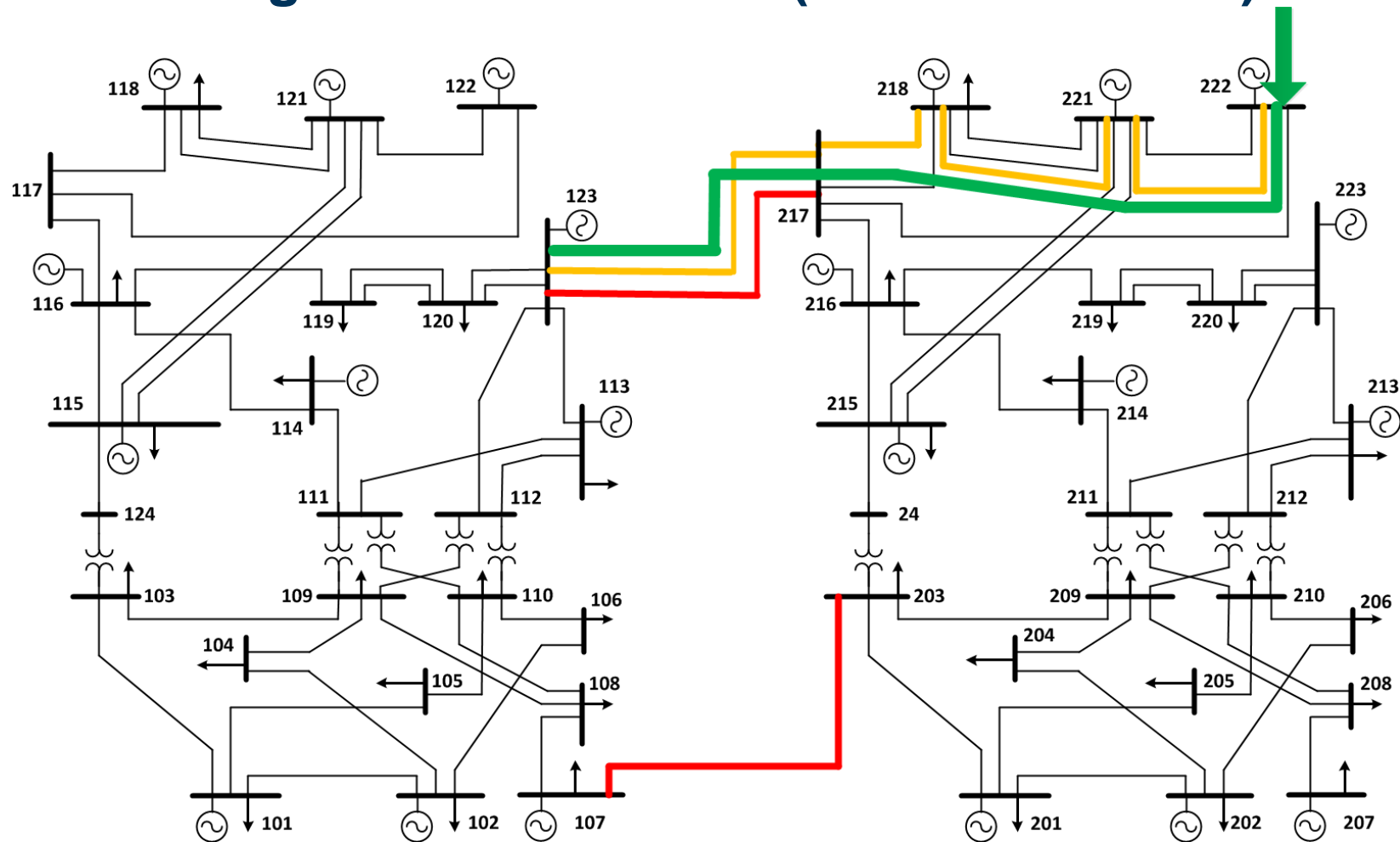

Overlay vs. Local Reinforcements

Three existing interconnections (2 x 230 kV & 138 kV)

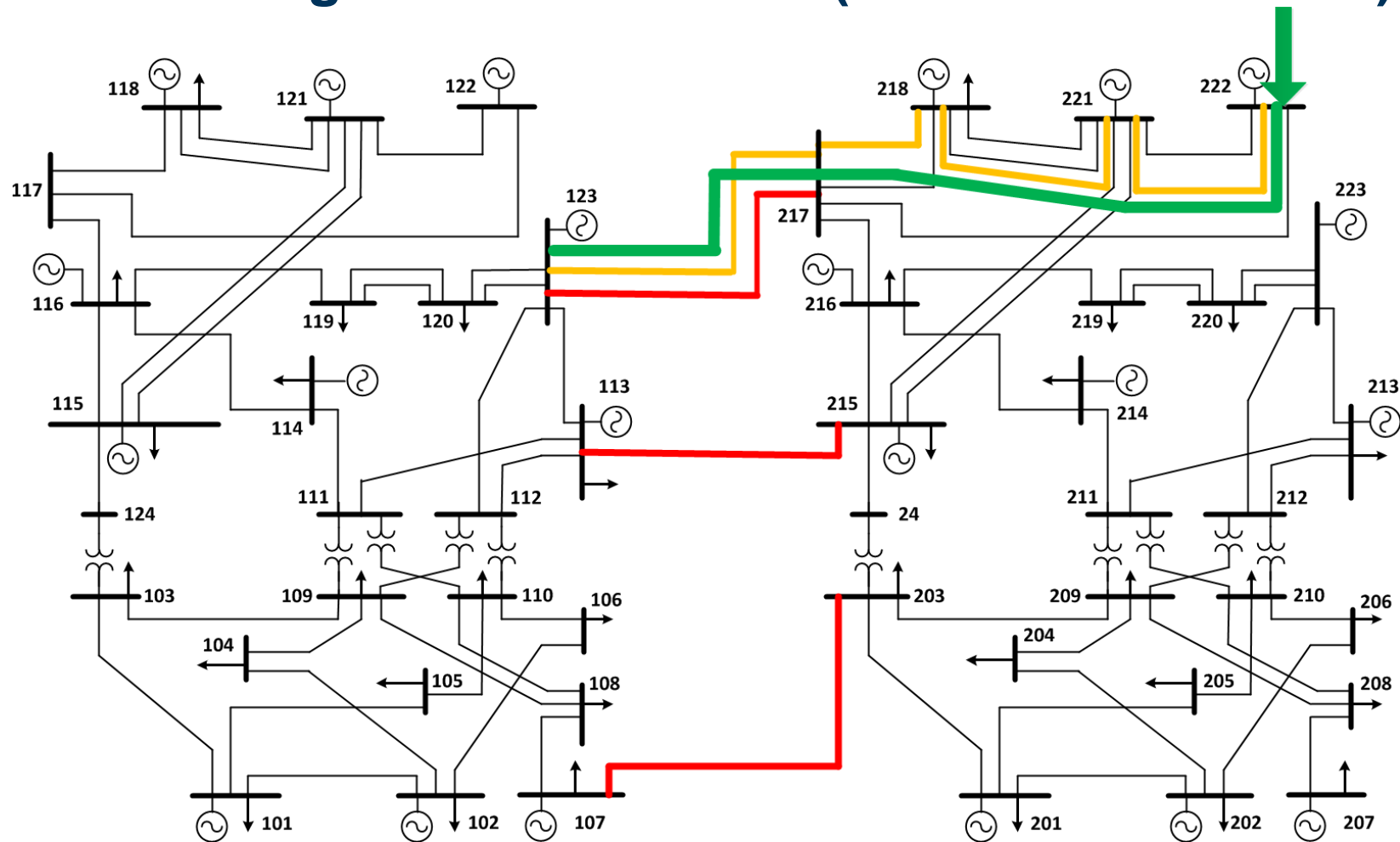

Maximum Power Transfer from bus #222 All additional lines on the same voltage level

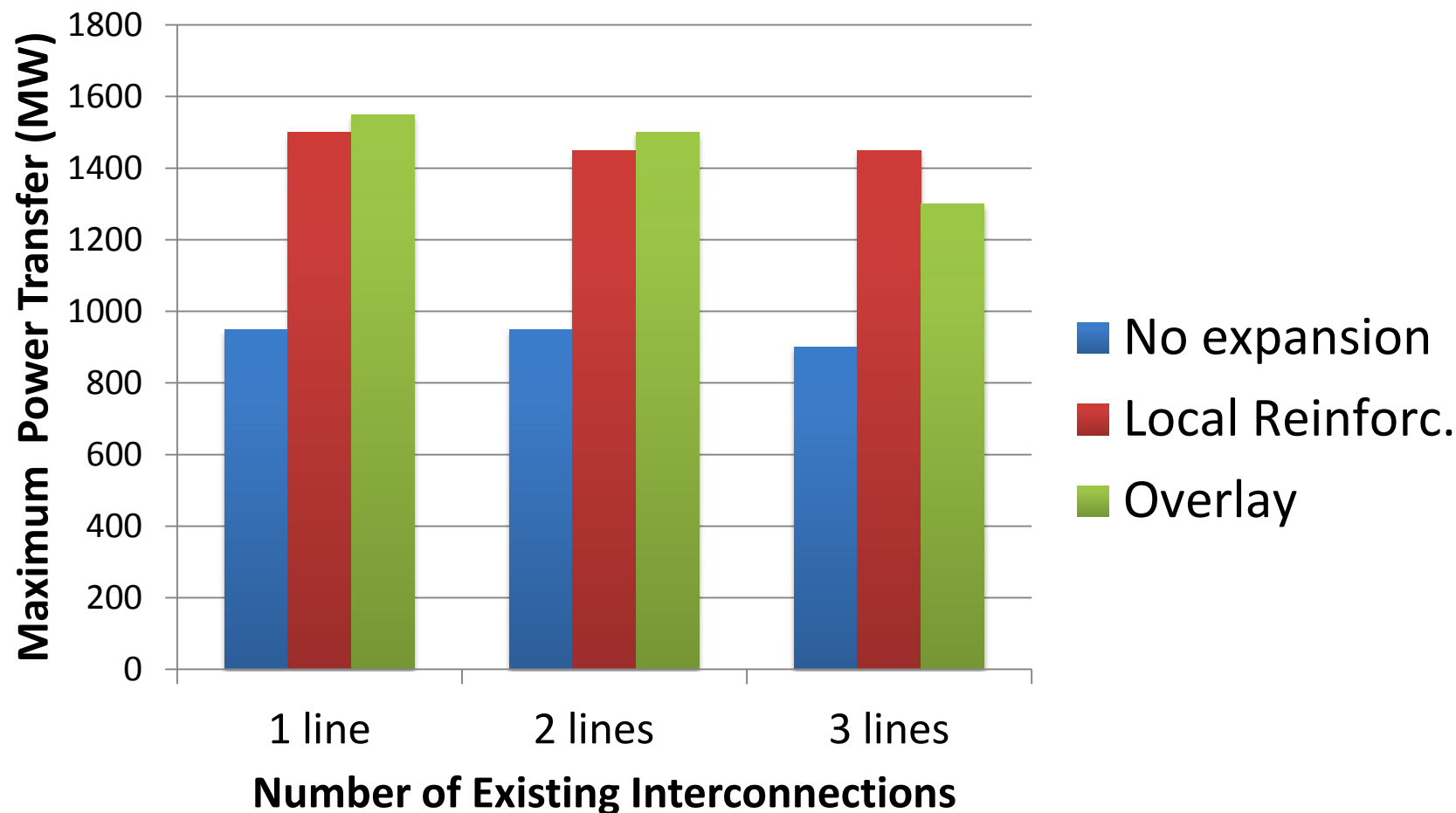

Maximum Power Transfer from bus #222

Overlay network on higher voltage level

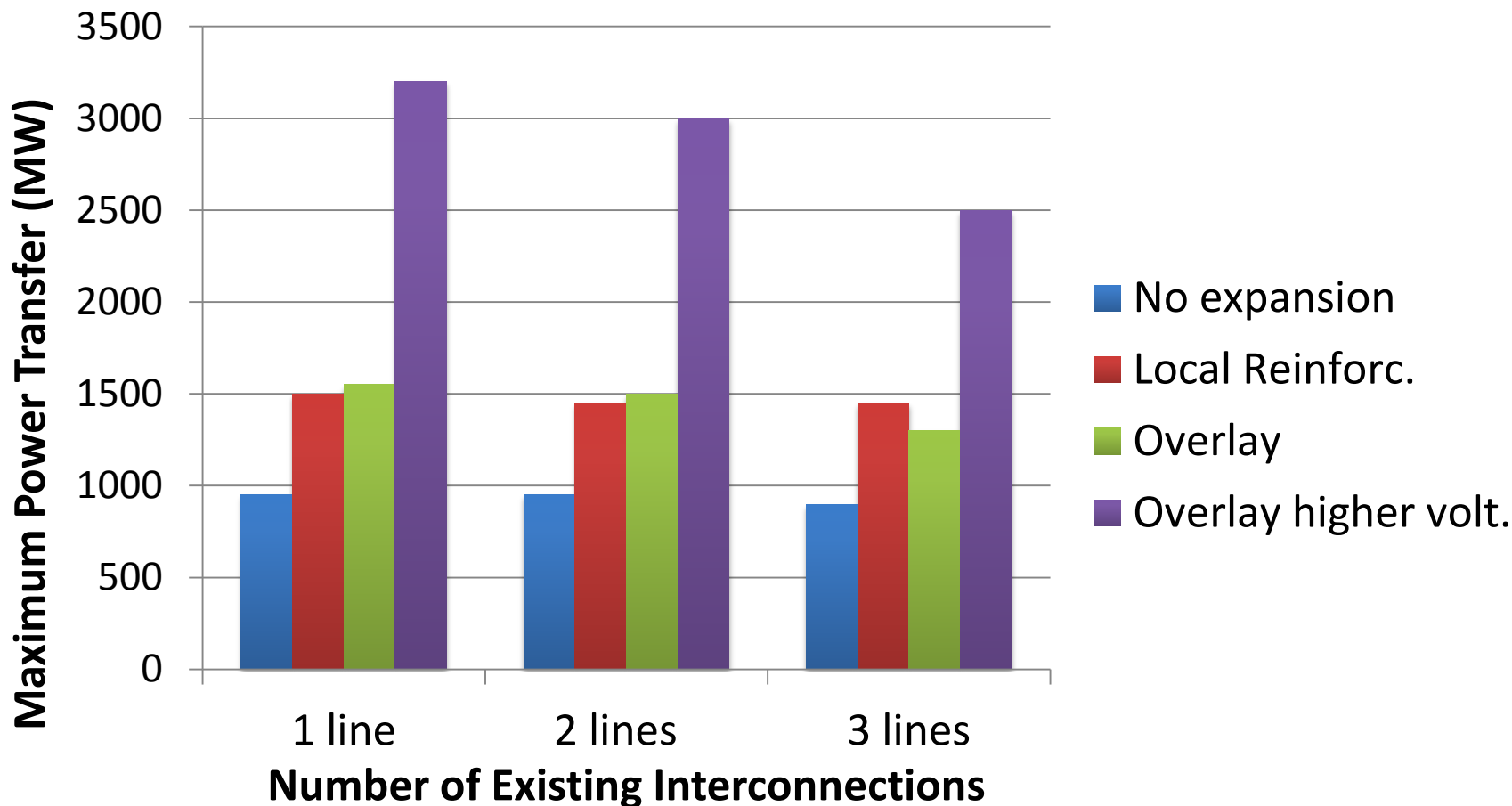

Upper bound on utilization of AC overlay lines

$$I_{OL} \leq I_{ICN}$$

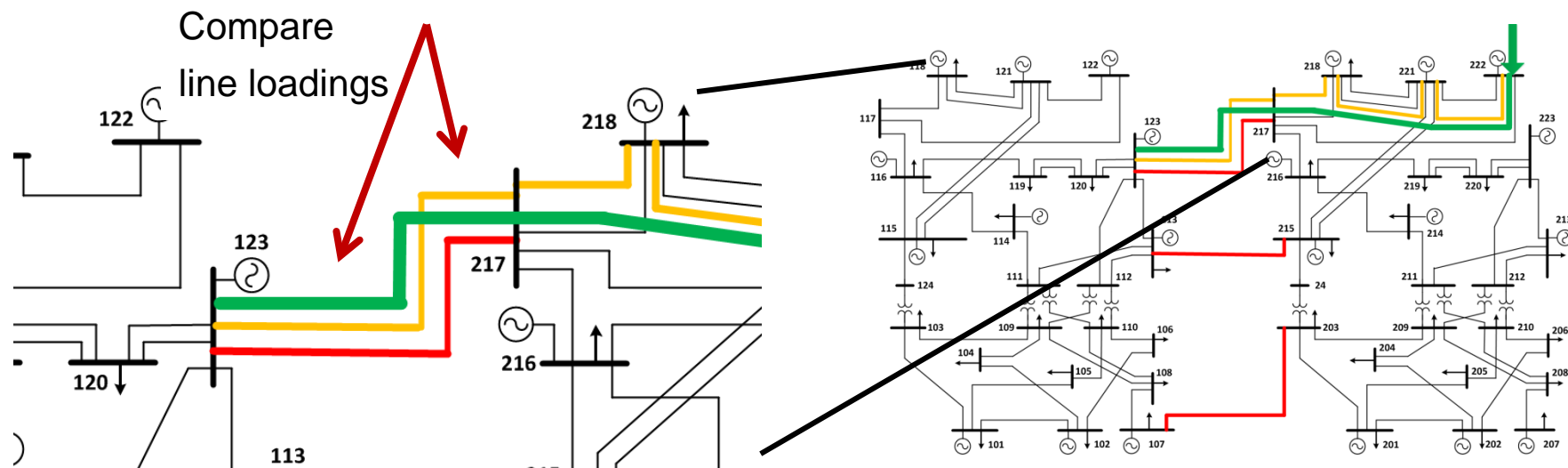
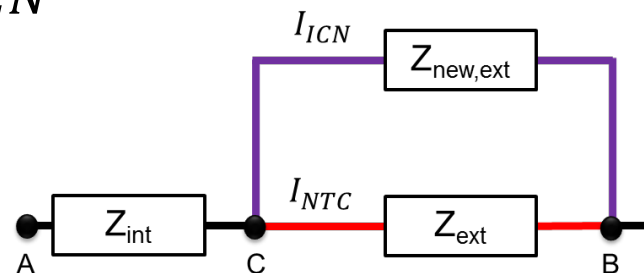
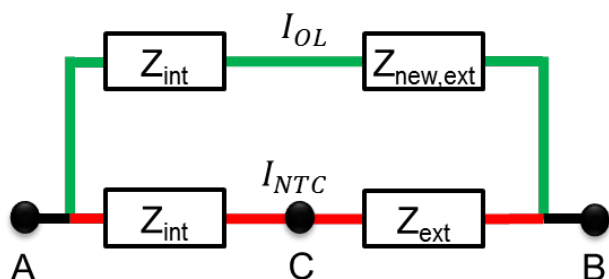

Upper bound on utilization of AC overlay lines

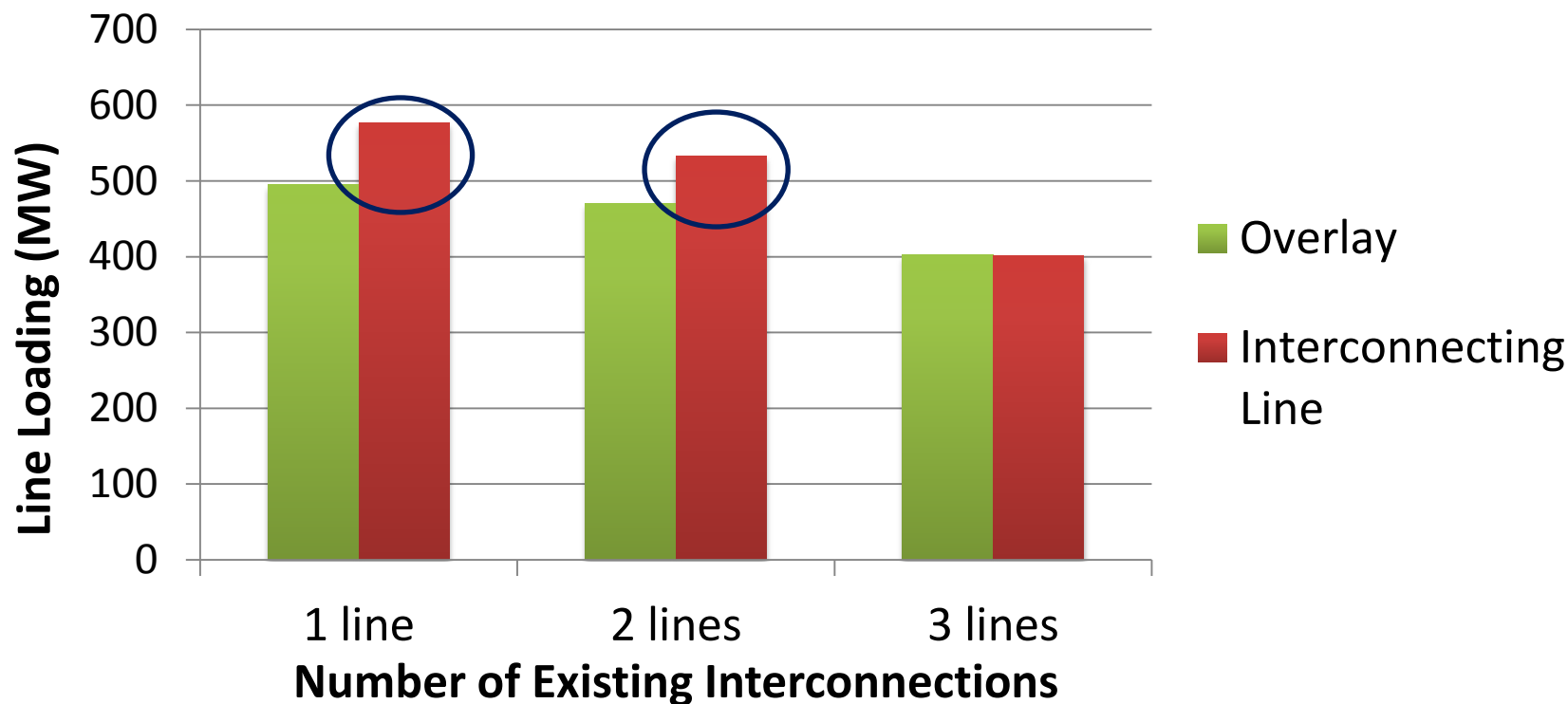

- Additional Remark: with increasing level of interconnections, the utilization of the AC overlay lines decreases
→ need for controllable power flows

OUTLINE

AC Expansion

1. Derivation of the Analytical Relationships
2. Case Study: RTS-96 Two-Area System

AC vs. HVDC

3. Yearly Simulations on European Network
4. Conclusions

Case Study

- Single-node per country;
real network data (UCTE)
- Generation Scenario:
80% RES in 2050
- Addition of 19 new AC or
HVDC lines

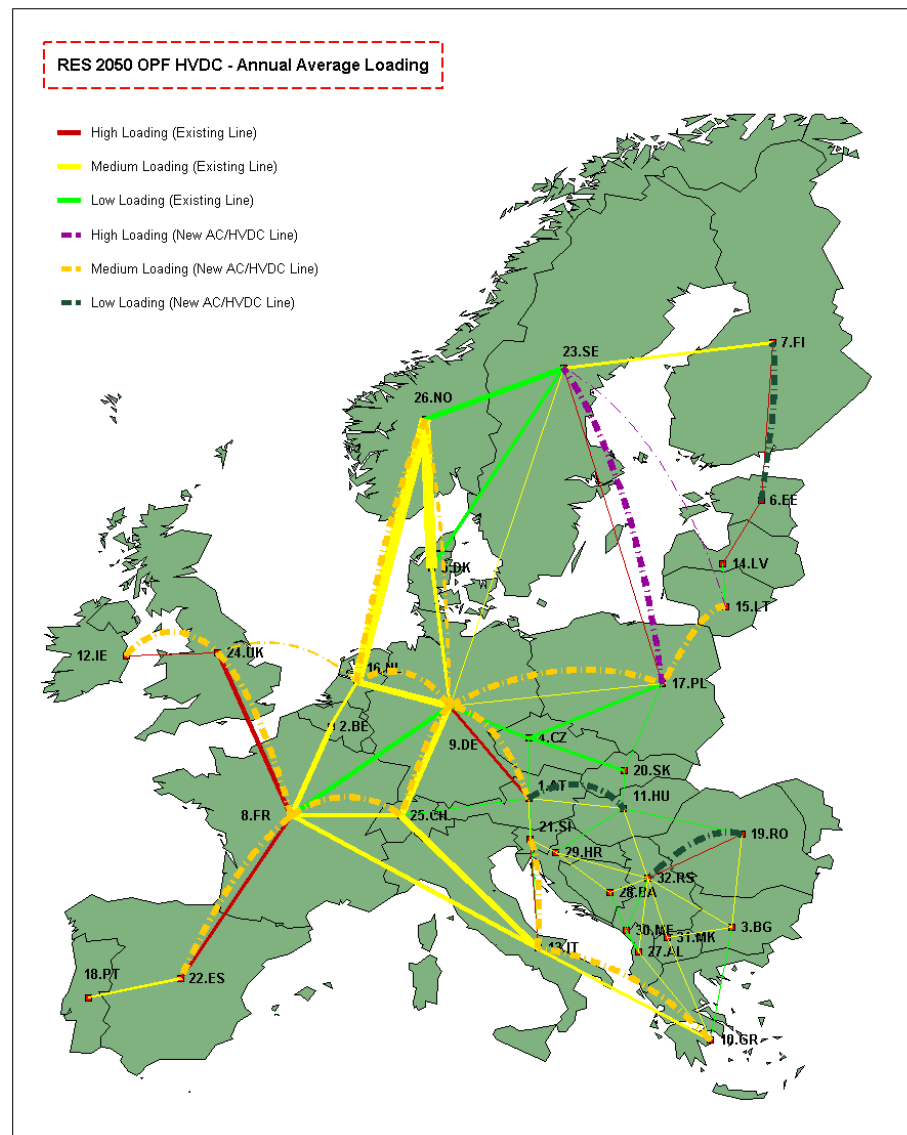

Maximum Utilization of New Lines for Different Expansion Options

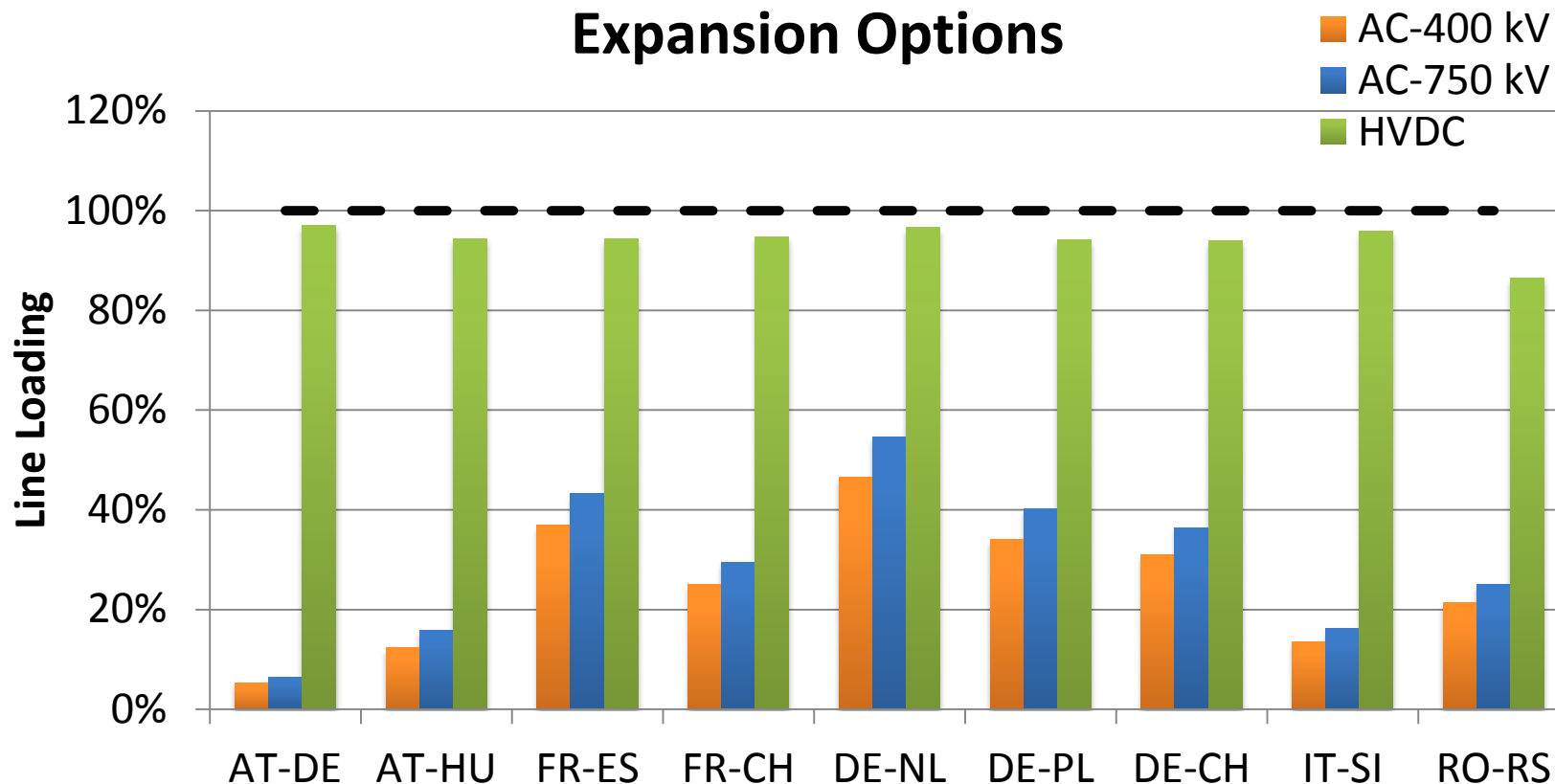

Highly Meshed Underlying Grids do not allow high utilization of Overlay AC Networks without FACTS

Annual Operating Costs

HVAC-400kV

10 AC lines + 9 submarine HVDCs

Cost = 95.3 billion Euros

Reduction = 10.3%

RES 2050 OPF AC-400kV - Annual

- High Loading (Existing Line)
- Medium Loading (Existing Line)
- Low Loading (Existing Line)
- High Loading (New AC/HVDC Line)
- Medium Loading (New AC/HVDC Line)
- Low Loading (New AC/HVDC Line)



UHVAC-750kV

10 AC lines + 9 submarine HVDCs

Cost = 94.0 billion Euros

Reduction = 11.5%

RES 2050 OPF AC-750kV - Annual

- High Loading (Existing Line)
- Medium Loading (Existing Line)
- Low Loading (Existing Line)
- High Loading (New AC/HVDC Line)
- Medium Loading (New AC/HVDC Line)
- Low Loading (New AC/HVDC Line)



HVDC

19 HVDC lines

Cost = 88.7 billion Euros

Reduction = 16.5%

RES 2050 OPF HVDC - Annual

- High Loading (Existing Line)
- Medium Loading (Existing Line)
- Low Loading (Existing Line)
- High Loading (New AC/HVDC Line)
- Medium Loading (New AC/HVDC Line)
- Low Loading (New AC/HVDC Line)

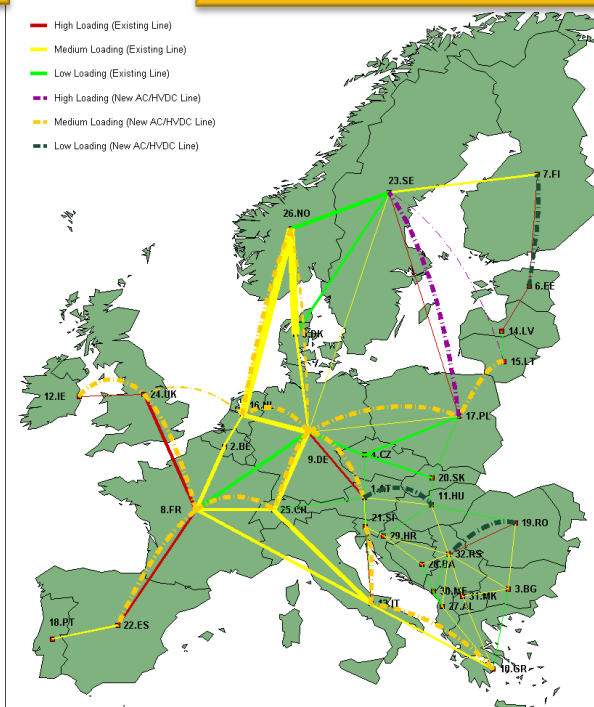

No Expansion: Annual Operating Cost = 106.3 billion Euros

Conclusions

- Analytically shown:
 - For weakly interconnected meshed power systems, overlay networks are preferable.*
- Derived an upper bound on utilization of overlay AC lines (over weakly interconnected meshed power systems)
- Controllable power flows are necessary over meshed power systems
 - Higher utilization of the installed lines
 - HVDC lines can save up to 8 billion Euros/year in operating costs for the European system

Thank you!

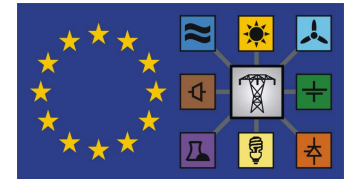

www.irene-40.eu

ETHEidgenössische Technische Hochschule Zürich
Swiss Federal Institute of Technology Zurich**Spyros Chatzivasileiadis**

Dipl.-Ing.

EEH - Power Systems LaboratoryETH Zurich
ETL G23
Physikstrasse 3
8092 Zurich
Switzerlandphone +41 44 632 89 90
fax +41 44 632 12 52
spyros@eeh.ee.ethz.ch
<http://www.eeh.ee.ethz.ch>